



---

# *TOOL DESIGNS & APPLICATIONS*

---

MANUFACTURER OF CONSTANT VELOCITY DRIVEAXLE COMPONENTS  
1500 11TH AVENUE ROCKFORD, ILLINOIS 61104  
PHONE (815) 962-1411 FAX (815) 962-4857

**Driveaxle Service Items**

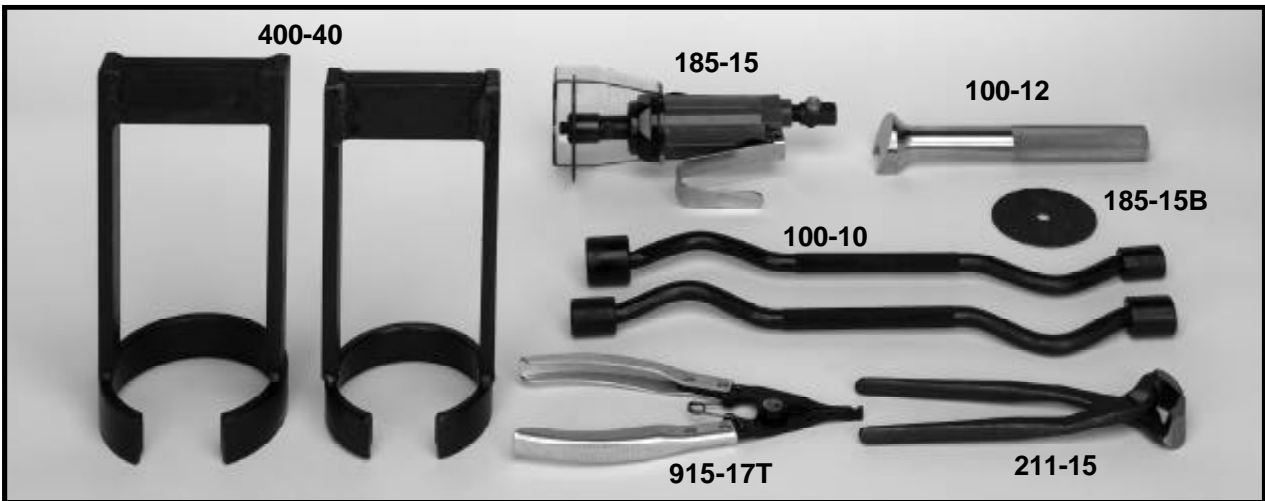

<b>PART #</b>	<b>DESCRIPTION</b>
100-10	<b>CV Joint Bearing Removal Tool</b> - Rotates The Race Allowing You To Remove The Bearings And Cage
100-12	<b>Inner Race Driver</b> - Aids In Removing Internal Clip Type Joints
185-15	<b>Pneumatic Cut Off Tool</b> - For Cutting Cage & Race Off Of Shaft
185-15B	<b>Pneumatic Cut Off Tool Replacement Wheel</b>
211-15	<b>Side Cutters</b> - For General Use
400-40	<b>GM Boot Seal Ring Installer Set</b> - Used To Remove And Install The Boot Retaining Rings Found On Many Early GM Axles
915-17T	<b>Snap Ring Pliers</b> - Use To Disengage Flat Faced Snap Rings

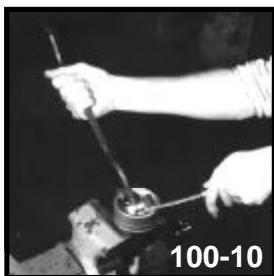

**100-10**  
**C.V. Joint Disassembly**  
**Tool: Fits All FWD**



**100-12**  
**Inner Race Driver: For**  
**Removal of Joints With**  
**Frozen Internal Snap**  
**Rings**



**185-15**  
**Pneumatic Cut Off**  
**Tool: Joint Removal**  
**When Internal Circlips**  
**Lock Joint On Shaft**



**211-15**  
**Side Cutters: For**  
**General Use**



**400-40**  
**GM Boot Retainer**  
**InstallerSet: Heavy**  
**Duty Construction**

**Polishing Materials**

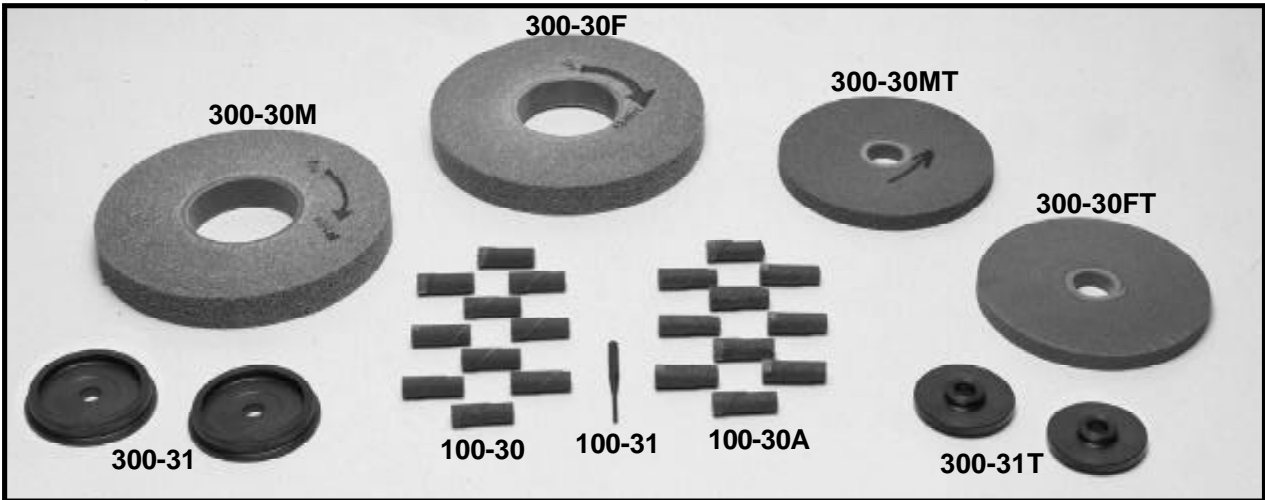

PART #	DESCRIPTION
100-30	Cartridge Rolls (Pkg of 10) - Fine - 120 Grit
100-30A	Cartridge Rolls (Pkg of 10) - Course - 60 Grit
100-31	Arbor For Cartridge Rolls
300-30F	Buffing Wheel - Fine 8" OD - 1" Thick
300-30FT	Buffing Wheel - Fine 6" OD - 1/2" Thick
300-30M	Buffing Wheel - Medium 8" OD - 1" Thick
300-30MT	Buffing Wheel - Medium 6" OD - 1/2" Thick
300-31	1/2" Arbor for 8" Wheel - (Set of Two)
300-31T	1/2" Arbor for 6" Wheel - (Set of Two)



**Cartridge Roll & Arbor  
Assembly: For Polishing  
Ball Wear in Joints**



**Buffing Wheel & Arbor  
Assembly: For Polishing  
Ball Wear in Races**

***Banding & Clamping Materials***

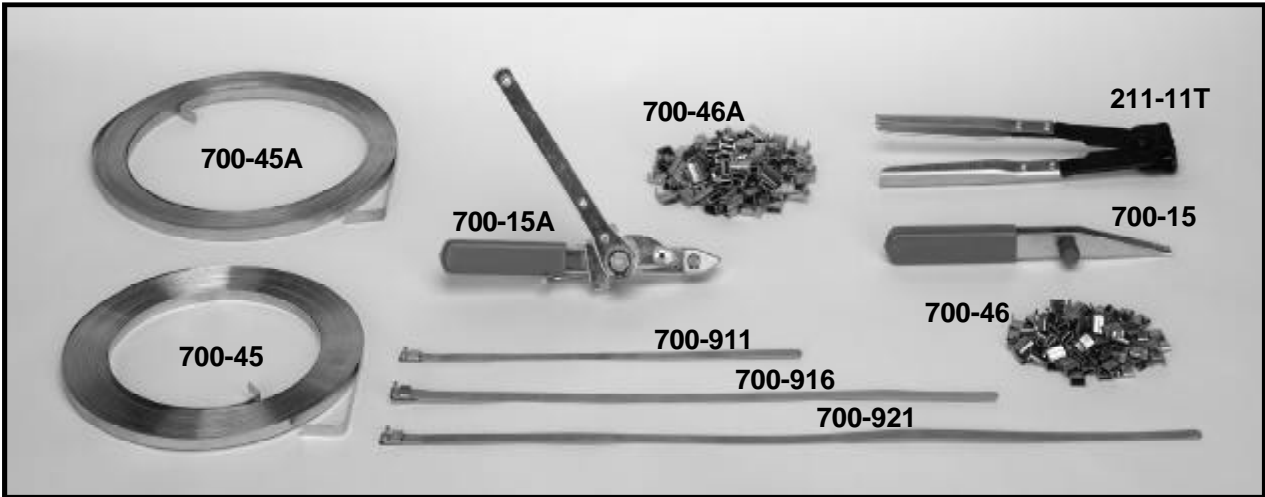

<b>PART #</b>	<b>DESCRIPTION</b>
211-11T	<b>Banding Tool</b> - Used For Crimp Type Clamps
700-15	<b>Banding Tool</b> - Used For Strap Type Clamps
700-15A	<b>Banding Tool (Ratchet Design)</b> - Used For Strap Type Clamps
700-45	<b>Stainless Steel Band</b> - 100' Roll, 5/16" Wide
700-45A	<b>Stainless Steel Band</b> - 100' Roll, 3/8" Wide
700-46	<b>Steel Band Clips</b> - Pkg Of 100 Fits 5/16" Wide Band
700-46A	<b>Steel Band Clips</b> - Pkg Of 100 Fits 3/8" Wide Band
700-911	<b>Band Straps</b> - 11" Long, 5/16" Wide (Pkg Of 6)
700-916	<b>Band Straps</b> - 16" Long, 3/8" Wide (Pkg Of 6)
700-921	<b>Band Straps</b> - 21" Long, 3/8" Wide (Pkg Of 6)



**Banding Tool: For  
Strap Type Clamps**



**Banding Tool: For  
Crimp Type Clamps**

**Tools**

***Axle Shaft Removal and Installation Items***

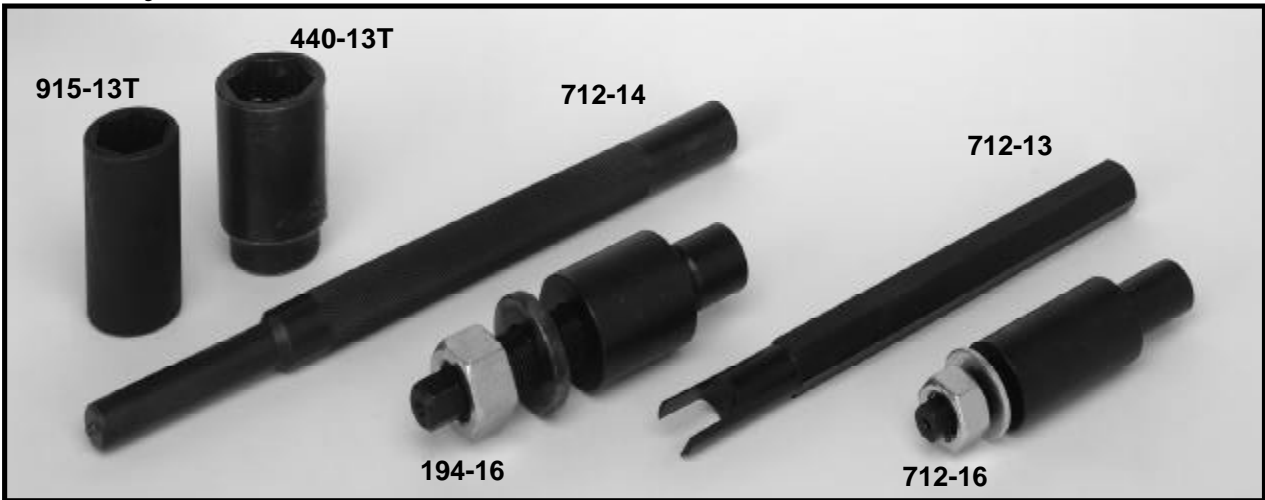

<b>PART #</b>	<b>DESCRIPTION</b>
194-16	<b>Hub Installer Tool</b> - Pulls The CV Thru The Hub On Subaru's
440-13T	<b>Deep Well Socket</b> - 36mm
712-13	<b>Shaft Removal Tool</b> - Allows You To Remove The Drivers Side Shaft Thru The Transaxle On Ford Applications
712-14	<b>OB Joint Punch</b> - Remove The Joint From Hubs W/O Damaging The Stub (Ford And Subaru Applications)
712-16	<b>Hub Installer Tool</b> - Pulls The CV Thru The Hub On Ford's
915-13T	<b>Deep Well Socket</b> - 30mm

***Crossgroove Assembly Tools***



<b>PART #</b>	<b>DESCRIPTION</b>
100-21T	<b>Crossgroove Assembly Tool Set</b>
100-21TA	<b>Crossgroove Assembly Tool</b> - Beretta
100-21TB	<b>Crossgroove Assembly Tool</b> - Lemans Auto
100-21TC	<b>Crossgroove Assembly Tool</b> - Lemans Man & Bravada

***Axle Shaft Removal and Installation Items***



<b>PART #</b>	<b>DESCRIPTION</b>
200-20	<b>Thread Die Set</b> - Includes Holder & 11 Solid Dies
200-20S	<b>Thread Die Set</b> - Includes Holder & 11 Split Dies
200-20A	<b>Die (26 x 1.25mm)</b> - GM (Eldorado & Toronado 67-78)
200-20AS	<b>Split Die (26 x 1.25mm)</b> - Same as Above
200-20B	<b>Die (24 x 1.5mm)</b> - Acura CL, (Legend 87-90) & Vigor, AMC Eagle, GM (Eldorado & Toronado 79-85), Honda (Accord & Prelude 90-up), Nissan (Stanza & Maxima 87-up), Subaru (exc. SVX, XT6 & Justy)
200-20BS	<b>Split Die (24 x 1.5mm)</b> - Same as Above
200-20C	<b>Die (22 x 1.5mm)</b> - Acura Integra, Audi 100 & 5000, BMW, Chrysler Domestic (exc. LH Body) & Imports, Diahatsu, Ford Contour, (Escort 92-96), Explorer, (Probe 88-98), T-Bird, Honda (Accord & Prelude 72-89), (Civic 80-98), Hyundai, Infinity G20, Kia Sephia, Lexus ES300, Mazda (MX6, Protege, 626 88-98), Mitsubishi, Nissan (Altima, Pulsar, Sentra 87-97), Saab 9000, Subaru Forester, Legacy, Impreza, SVX & XT, Toyota Paseo & Previa
200-20CS	<b>Split Die (22 x 1.5mm)</b> - Same as Above
200-20D	<b>Die (20 x 1.5mm)</b> - Audi (exc. 5000), Eagle Medallion & Premier, Ford Aspire, Festiva, Probe 83-87, Taurus, Tempo & Windstar, GM With 3/4" Thread Dia 80-99, Mazda (MX6 & 626 83-87), Renault, Subaru Justy 89-94, Volkswagen
200-20DS	<b>Split Die (20 x 1.5mm)</b> - Same as Above
200-20E	<b>Die (24 x 2.0mm)</b> - GM With 1" Thread Dia 82-99 Including 4x4 Trucks
200-20ES	<b>Split Die (24 x 2.0mm)</b> - Same as Above
200-20F	<b>Die (19 x 1.5mm)</b> - Toyota Camry, Celica, Corolla & Tercel
200-20FS	<b>Split Die (19 x 1.5mm)</b> - Same as Above
200-20G	<b>Die (22 x 1.0mm)</b> - Datsun 310/F10, Mazda 929, Nissan (Pulsar, Sentra, Stanza 82-86)
200-20GS	<b>Split Die (22 x 1.0mm)</b> - Same as Above
200-20H	<b>Thread Die Holder</b> - Handle Only
200-20I	<b>Die (18 x 1.5mm)</b> - Chevy Metro & Sprint, Geo Metro, Subaru Justy 87-88, Suzuki Swift
200-20IS	<b>Split Die (18 x 1.5mm)</b> - Same as Above
200-20J	<b>Die (20 x 1.0mm)</b> - GM LeMans & Spectrum, Geo Storm, Isuzu I-Mark, Impluse & Stylus
200-20JS	<b>Split Die (20 x 1.0mm)</b> - Same as Above
200-20K	<b>Die (27 x 2.0mm)</b> - Chrysler LH Body, GM (C Body & H Body 91-95)
200-20KS	<b>Split Die (27 x 2.0mm)</b> - Same as Above
200-20L	<b>Die (26 x 1.5mm)</b> - Acura Legend 91-95
200-20LS	<b>Split Die (26 x 1.5mm)</b> - Same as Above

**Tools**

***Benchwork Tools: Air Vice***



<b>PART #</b>	<b>DESCRIPTION</b>
100-11	<b>Pneumatic Air Vice</b> - (Foot pedal allows for hands free operation)

***Benchwork Tools: Bushing Driver***



<b>PART #</b>	<b>DESCRIPTION</b>
176-E6	<b>Disk Joint Bushing Installer/Remover</b> - (Toyota Previa Equipment Drive Shafts)

***Benchwork Tools: Seal Driver***



<b>PART #</b>	<b>DESCRIPTION</b>
412-2T	<b>Seal Driver</b> - for Late Model Spicer Design Stud Yokes - (Use On 412-2 Dust Shield)

***Benchwork Tools: Crimping Fixtures & Repair Parts***

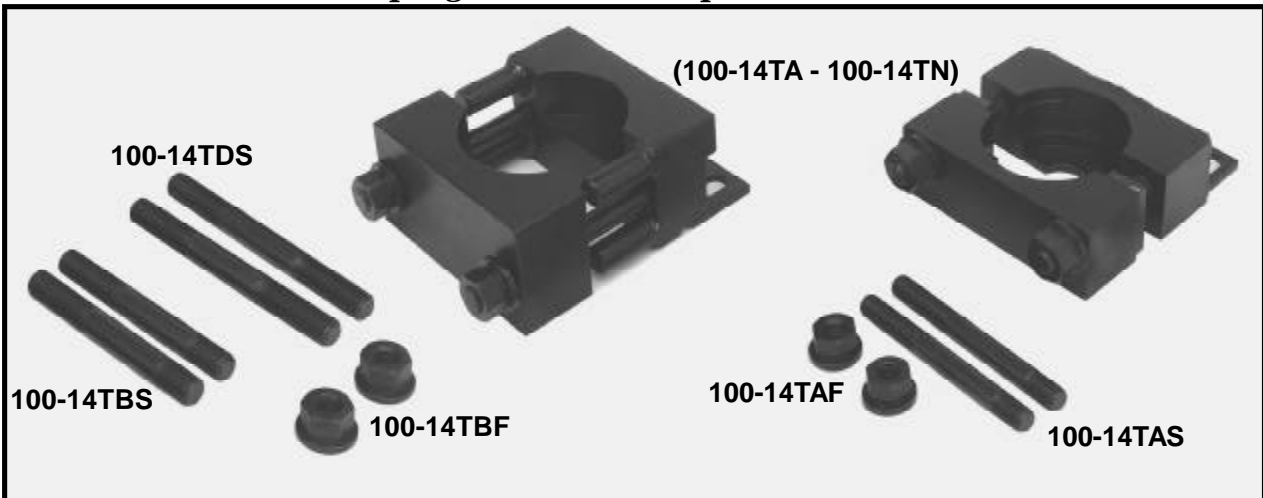

<b>PART #</b>	<b>DESCRIPTION</b>
100-14TA	<b>Crimping Fixture</b> - ACI Chrysler, ACI Ford Tempo (214-15 Boot Flange)
100-14TAF	<b>Replacement Flange Nut (Ea.)</b> - Fits 1/2" Stud
100-14TAS	<b>Replacement Stud (Ea.)</b> - 1/2" x 5"
100-14TB	<b>Crimping Fixture</b> - Pontiac LeMans RH Auto Trans (712-3A Boot Assembly)
100-14TBF	<b>Replacement Flange Nut (Ea.)</b> - Fits 5/8" Stud
100-14TBS	<b>Replacement Stud (Ea.)</b> - 5/8" x 5"
100-14TC	<b>Crimping Fixture</b> - Pontiac LeMans Manual Trans (712-4A Boot Assembly)
100-14TD	<b>Crimping Fixture</b> - Nissan 300ZX Non-Turbo (280-4 Boot Assembly)
100-14TDS	<b>Replacement Stud (Ea.)</b> - 5/8" x 6"
100-14TE	<b>Crimping Fixture</b> - Mercedes Benz (230-4 Boot Assembly)
100-14TF	<b>Crimping Fixture</b> - Ford Taurus ACI, Mercury Sable ACI (715-15 Boot Flange)
100-14TG	<b>Crimping Fixture</b> - Chevrolet Camaro, Oldsmobile Bravada, Pontiac Firebird (421-10A & 421-10C Boot Assemblies)
100-14TH	<b>Crimping Fixture</b> - BMW 318i, BMW 325e (320-AS Boot Flange)
100-14TI	<b>Crimping Fixture</b> - Lincoln Continental (714-4AS Boot Flange)
100-14TJ	<b>Crimping Fixture</b> - Lexus GS300, LS400, SC300 & SC400 (550-4AS Boot Flange)
100-14TK	<b>Crimping Fixture</b> - Mercedes Benz (220-3AS Boot Flange)
100-14TL	<b>Crimping Fixture</b> - BMW 3 Series (804-4AS Boot Flange)
100-14TM	<b>Crimping Fixture</b> - Ford Thunderbird, Mercury Cougar (716-15 Boot Flange)
100-14TN	<b>Crimping Fixture</b> - BMW Lineshafts 99mm Joints (804-10A Boot Assembly)



# RINGMASTER™

**Installation Fixture:**



- **Install ABS Rings Onto The Housing Without Damage.**
- **Ensure Proper Function Of Anti-Lock System.**
- **Holder And Rings For 45 Applications.**

<b>PART #</b>	<b>DESCRIPTION</b>
100-20T	<b>RingMaster</b> (Complete Set)
100-20TA	<b>Driver Ring</b> - Installs 182-19, 335-19, 335-19A, 335-19B, 335-19C, 626-19A, 626-19B, 627-19A, 714-19C, 716-19, 719-19
100-20TB	<b>Driver Ring</b> - Installs 175-19, 183-19, 320-19, 335-19D, 441-19, 625-19, 627-19, 627-19B, 714-19A, 914-19
100-20TC	<b>Driver Ring</b> - Installs 176-19, 178-19, 214-19, 275-19, 550-19
100-20TD	<b>Driver Ring</b> - Installs 214-19A, 915-19
100-20TE	<b>Driver Ring</b> - Installs 166-19, 178-19A, 188-19, 216-19, 440-19, 440-19A, 441-19A, 714-19, 714-19B, 714-19D, 715-19, 815-19
100-20TF	<b>Driver Ring</b> - Installs 189-19, 189-19A, 216-19A, 627-19C
100-20TG	<b>Driver Ring</b> - Installs 816-19

***Benchwork Tools: CV Joint Press Repair Parts***

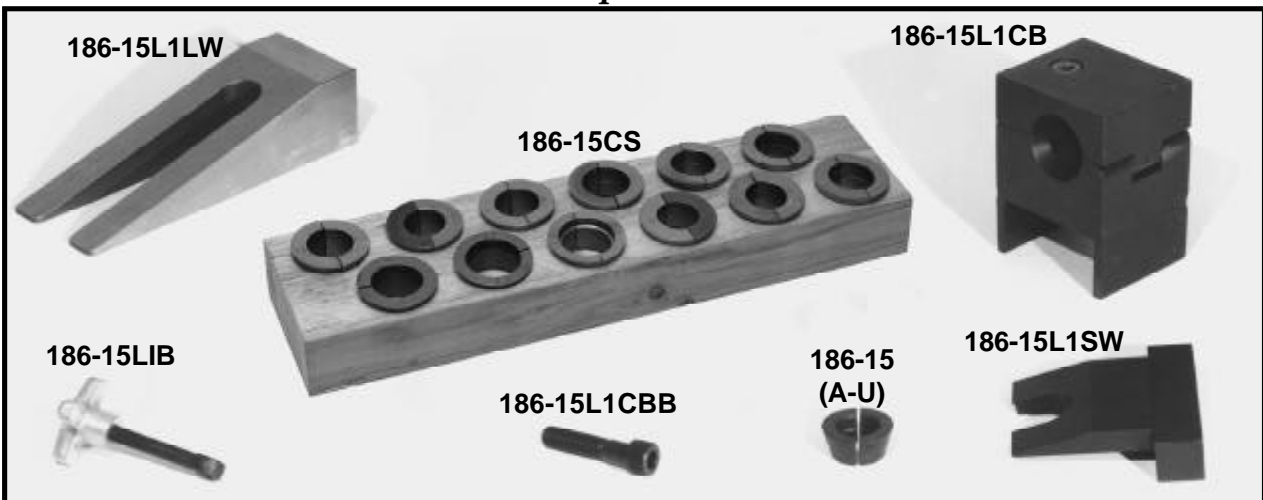

<b>PART #</b>	<b>DESCRIPTION</b>
186-15A	Replacement Collet - #1
186-15B	Replacement Collet - #2
186-15C	Replacement Collet - #3
185-15CS	Complete Set of Collets Includes Wood Storage Block
186-15D	Replacement Collet - #4
186-15E	Replacement Collet - #5
186-15F	Replacement Collet - #6
186-15G	Replacement Collet - #7
186-15H	Replacement Collet - #8
186-15I	Replacement Collet - #9

<b>PART #</b>	<b>DESCRIPTION</b>
186-15LIB	Shaft Retainer I Bolt Assembly
186-15L1CB	Collet Block
186-15L1CBB	Collet Block Bolt
186-15L1LW	Large Wedge
186-15L1SW	Small Wedge
186-15S	Replacement Collet - #10
186-15SRB	Shaft Retainer Block - (Not Pictured)
186-15T	Replacement Collet - #11
186-15U	Replacement Collet - #12
186-15V	Replacement Collet - #13

**Assembly Tools**



<b>PART #</b>	<b>DESCRIPTION</b>
100-13	<b>Transmission Support Bearing Installation Driver - (Except Chrysler)</b>
100-13A	<b>Transmission Support Bearing Removal &amp; Installation Tool - (Chrysler)</b>
271-13T	<b>Carrier Bearing Assembly Tool - (Alliance/Encore - Left Shafts)</b>
271-14	<b>Fixed Tripod Clip Installation Washer - (Alliance, Encore, Stanza)</b>
273-14	<b>Fixed Tripod Clip Installation Washer - (Renault Le Car)</b>
535-14	<b>Fixed Tripod Clip Installation Washer - (Toyota Tercel)</b>

*Extra Service Items*



<b>PART #</b>	<b>DESCRIPTION</b>
180-13	<b>Replacement Spindle Nut &amp; Spring Pins Kit</b> - Assortment of 17 Spindle Nuts & Spring Pins (194-14, 271-12 & 275-14 Pins, 163-13C, 163-13S, 164-13, 184-12, 194-13, 195-13, 213-13, 440-13, 441-13, 536-13, 712-12, 813-13 & 915-13 Spindle Nuts) in a durable storage box
180-16	<b>Replacement Snap Ring Kit</b> - Assortment of 18 popular internal snap rings (161-16, 163-16, 164-16, 174-16, 178-16, 184-16, 185-17, 211-16, 213-16, 214-17, 215-16, 275-16A, 536-17, 615-17, 625-15, 626-16, 627-16, 628-16, 713-17, 714-17, 716-16, 813-17A & 813-17) in a durable storage box
915-7B5	<b>C.V. Joint Grease</b> - 3.5 oz. Ea. (Pkg. of 5)
915-7B	<b>C.V. Joint Grease</b> - 3.5 oz. Ea. (Individual Packs)

***C.V. Driveaxle Grease: Dura-Grease & Pump Materials***

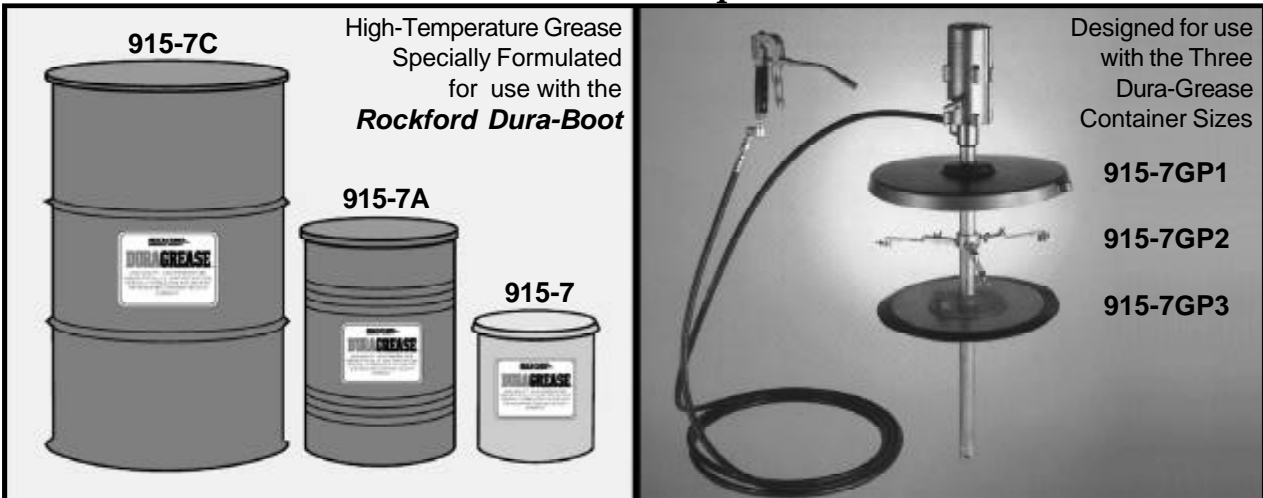

<b>PART #</b>	<b>DESCRIPTION</b>
915-7	C.V. Joint Dura-Grease - 35 Lbs.
915-7A	C.V. Joint Dura-Grease - 120 Lbs.
915-7B	C.V. Joint Dura-Grease - 3.5 Oz. Bag (Not Pictured)
915-7C	C.V. Joint Dura-Grease - 400 Lbs.
915-7GP1	Grease Pump - Fits 400 Lbs. Barrels
915-7GP2	Grease Pump - Fits 120 Lbs. Barrels
915-7GP3	Grease Pump - Fits 35 Lbs. Buckets
915-7GPG	Replacement Grease Pump Gun - (Not Pictured)
915-7GPH	Replacement Grease Pump Hose - (Not Pictured)
915-7GPK	Extra Gun Kit - (Not Pictured)
915-7GPZ	Replacement Grease Pump "Z" Swivel - (Not Pictured)

***Driveaxle Boxes : For Shipping Axles To Your Customers***

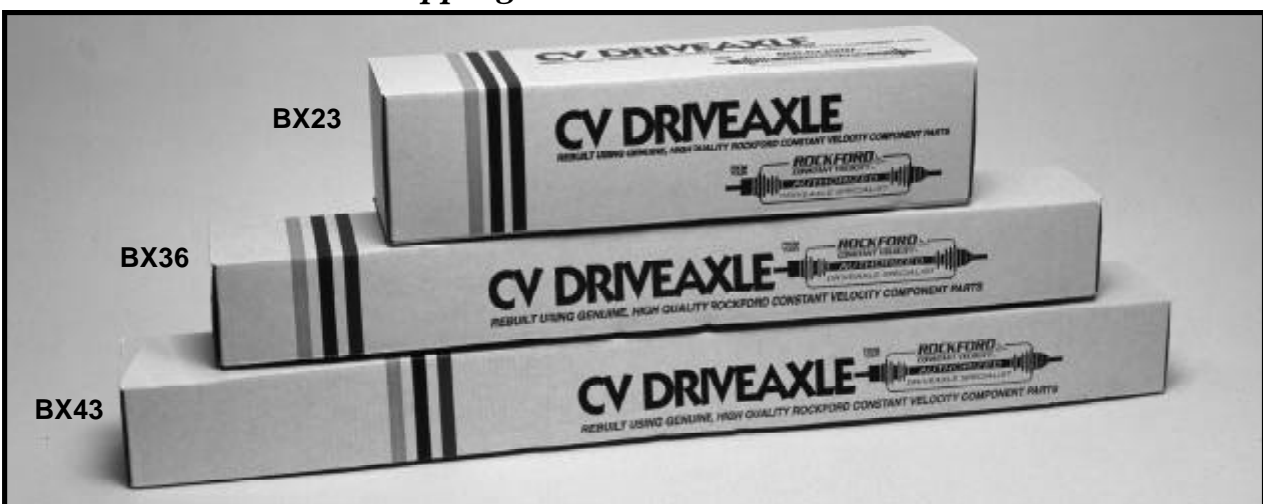

<b>PART #</b>	<b>DESCRIPTION</b>
BX23	25 Driveaxle Boxes - 23" x 6" x 6"
BX36	25 Driveaxle Boxes - 36" x 4" x 5"
BX43	25 Driveaxle Boxes - 43" x 4" x 5"

**Tools**